

PRESA DI FORZA A COMANDO PNEUMATICO

PNEUMATIC CLUTCH POWER TAKE-OFF

CODICE PTO
PTO CODE

10-75-170

CAMBIO
GEARBOX

ZF



DIAGRAMMA DI UTILIZZO WORKING CONDITION



Preso di forza con uscita non supportata. È necessario l'utilizzo di pompe con albero supportato.
PTO with loose gear output. Mounting only possible with hydraulic pumps having bearing on the shaft.

Data: Giovedì 13 aprile 2017

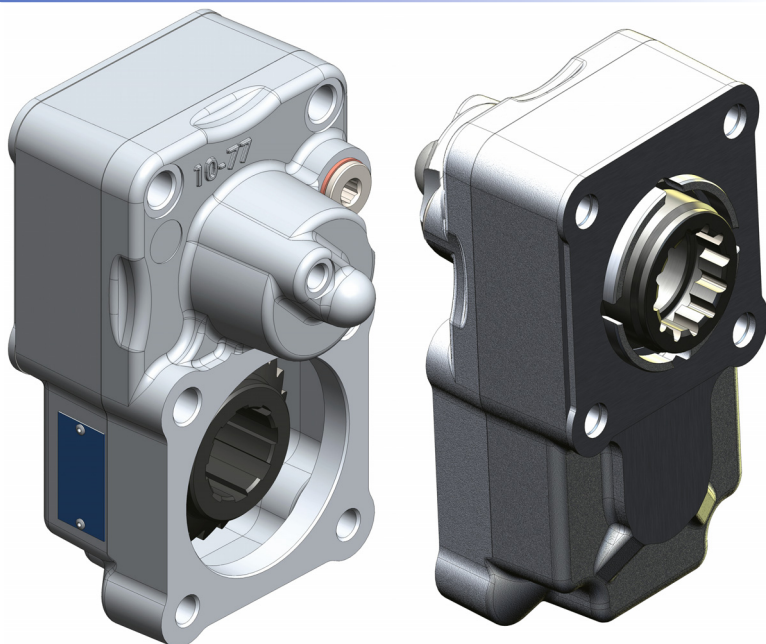
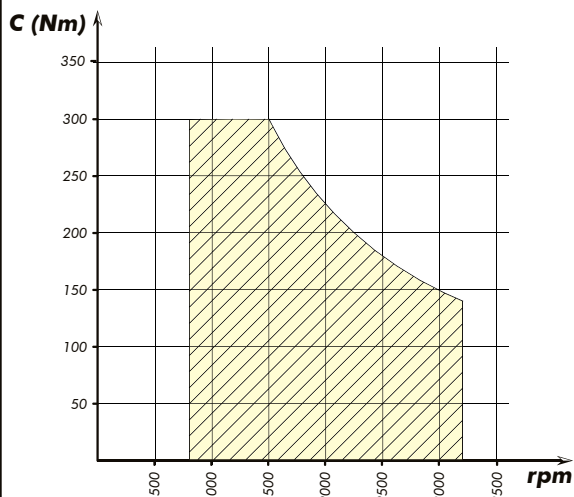
Codice foglio: 997-210-07517 Rev: AA

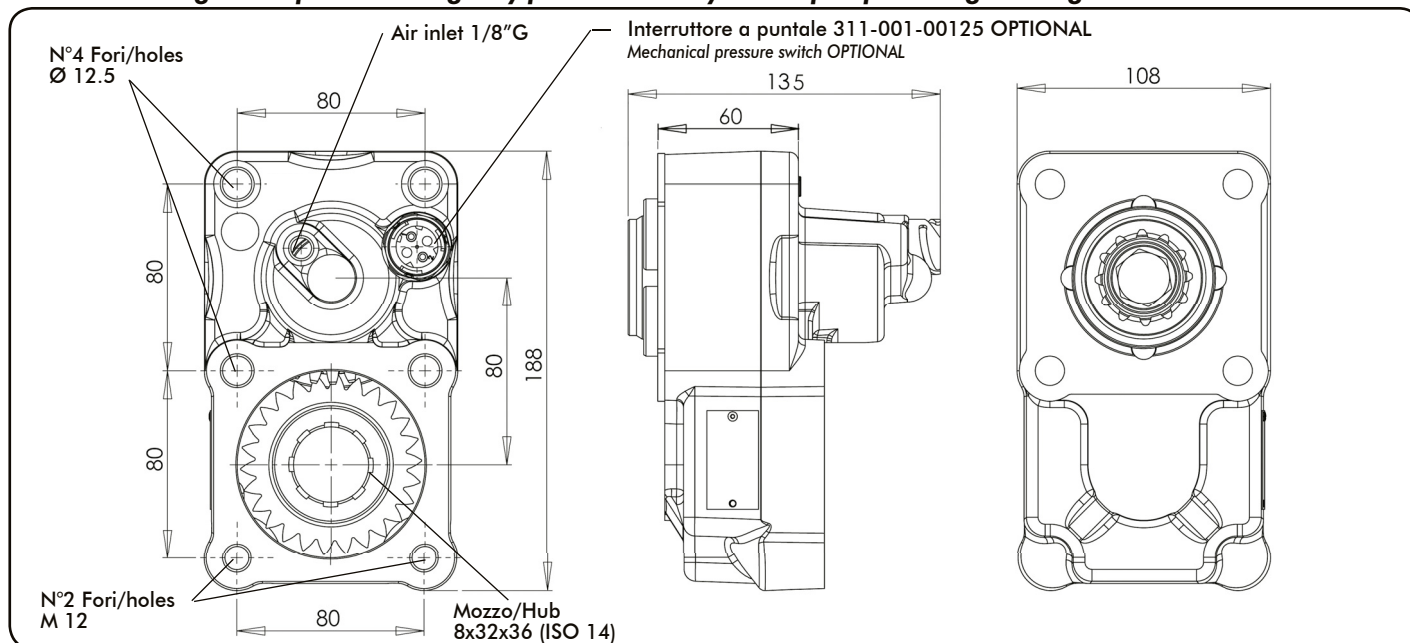

Tipo cambio Gearbox	Codice PTO PTO code	Versione Version	Giri pto a 1000 giri motore Pto ratio@1000 eng.rpm	Coppia massima Max torque	Lato montaggio Mounting side	Uscita Output	Rotazione Rotation	Kit di montaggio Mounting kit	Peso Weight
Vedi indice See index	10-75-00170	817	Vedi indice See index rpm	300 Nm	Poster. Rear	Poster. Rear	Ant. Acw	Vedi indice See index	4,34 Kg

Rapporto interno / Internal ratio = 1:1.35



pag.1

O.M.F.B. S.p.A. Hydraulic Components

We reserve the right to make any changes without notice.

Edition 2009.10 No reproduction, however partial, is permitted.

Via Cave, 7/9 25050 Provaglia d'Isèo (Brescia) Italy Tel.: +39.030.9830611
Fax: +39.030.9839207-208 Internet:www.omfb.it e-mail:info@omfb.it

**COMPANY WITH
QUALITY SYSTEM
CERTIFIED BY DNV GL
= ISO 9001 =**